

## Core Floorstanding Assembly Instructions

### Tools Required:

- Socket Driver
- 10mm Spanner *\*or adjustable spanner*

Sheet Code: BP-IM-092\_REV0  
Release Date: 15/08/2024

Copyright 2024 Spotspot Ltd. (T/A Bouncepad) all rights reserved. Confidential, no part of this publication may be reproduced or transmitted in any form without the written permission of the copyright holder.

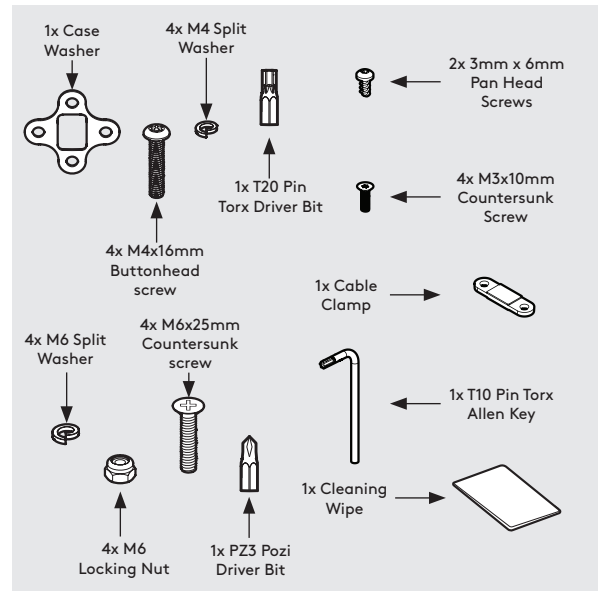
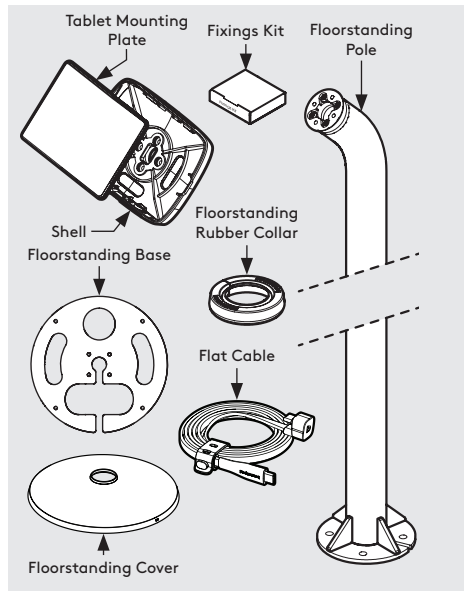

*\* Due to the modular nature of our product range you may receive additional fixings in the fixings list*

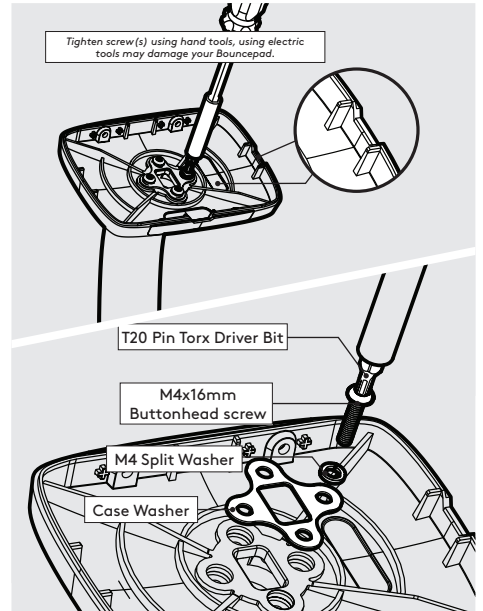
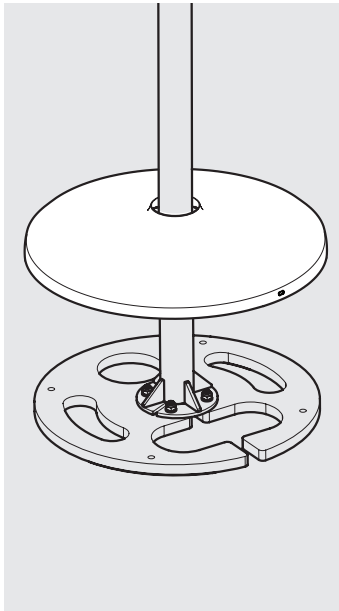
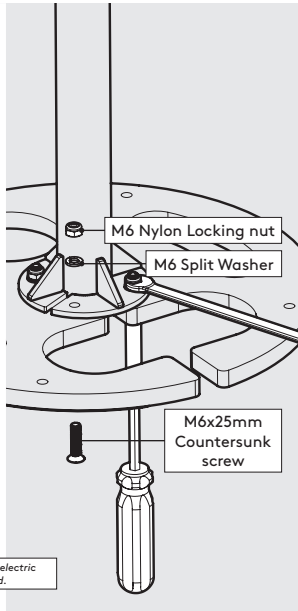
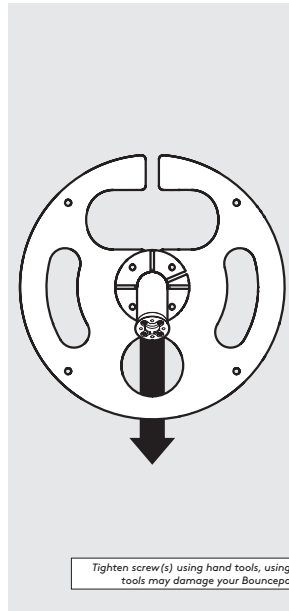

**1** Orientate, locate & secure the Floorstanding Pole to the Floorstanding Base as shown. Ensure that all fixings are installed correctly.

**2** Locate the Floorstanding Cover over the Floorstanding Pole.

**3** Locate & attach the Shell to the Floorstanding in the correct orientation.

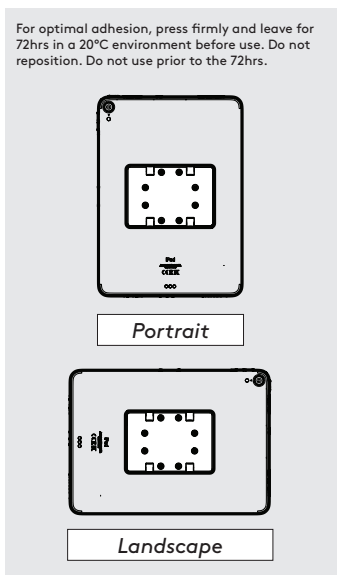
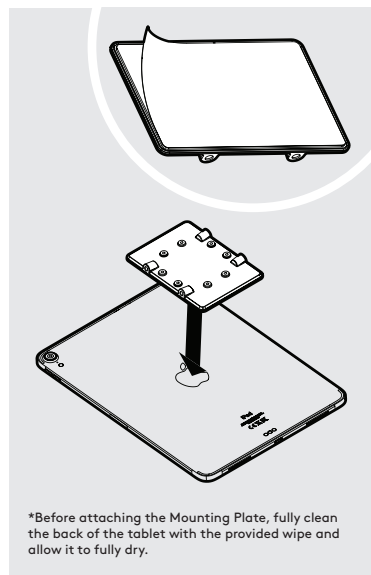

*\*Before attaching the Mounting Plate, fully clean the back of the tablet with the provided wipe and allow it to fully dry.*

**4** Remove the Mounting Plate adhesive backing. Attach level & centrally to the Tablet back as shown.

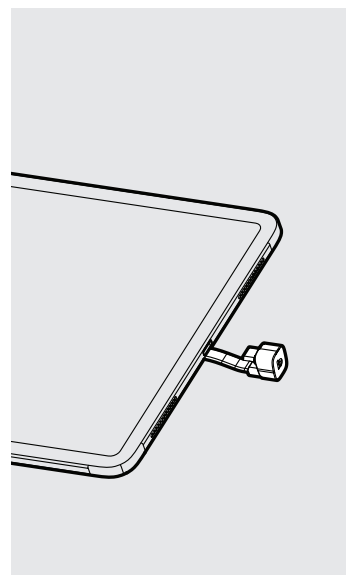

**5** Attach the Flat Cable to the Tablet with the U-Bend Head.

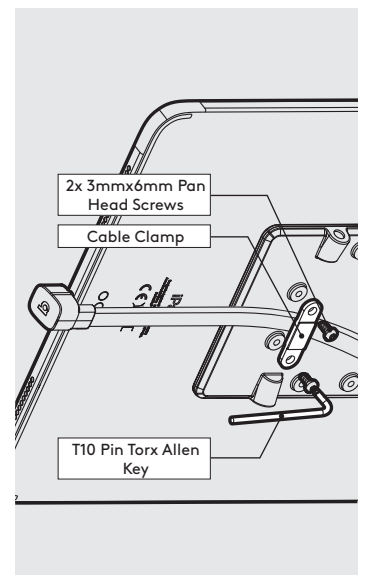

**6** Secure the Flat Cable to the Mounting Plate with the Cable Clamp as shown.

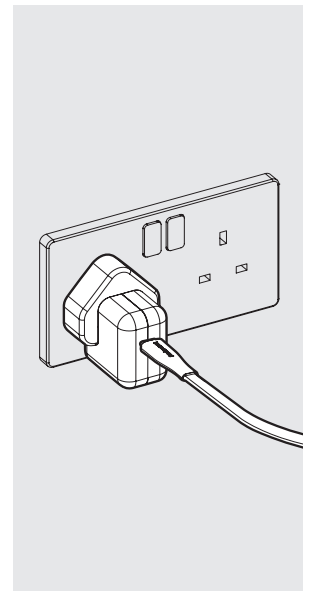
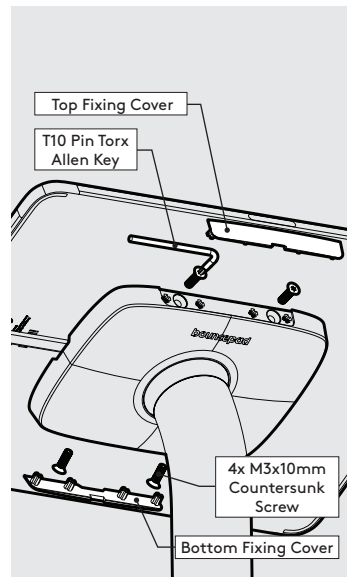
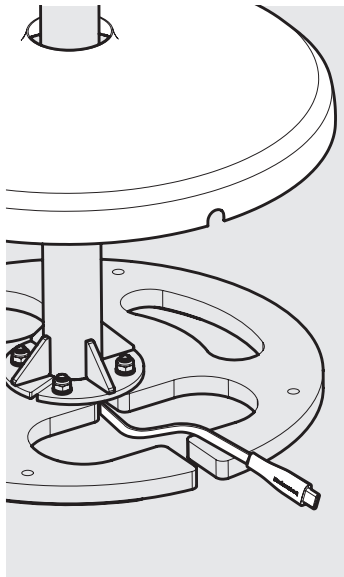
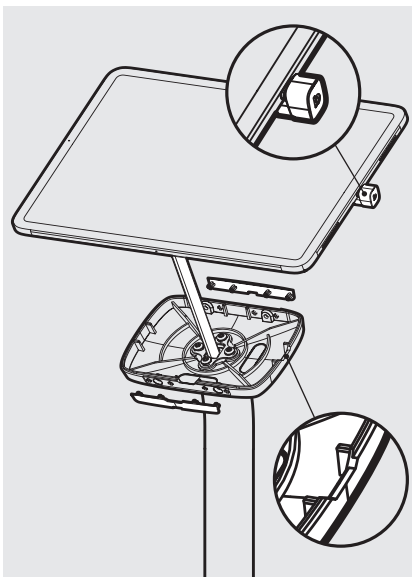

**7** Remove the Fixing Covers. Feed the Flat Cable into the assembly & locate the Tablet in the chosen orientation.

**8** Secure the Tablet to the Shell & attach the Fixing Covers as shown.

**9.1** Connect the tablet power cable to its mains power source.

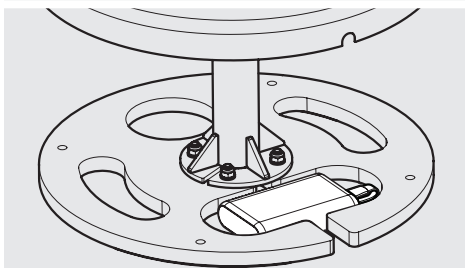
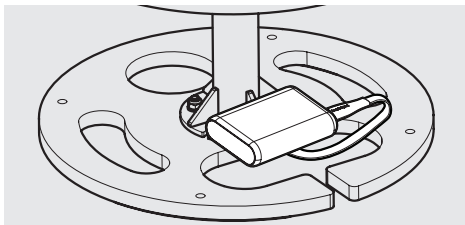

\*designed to support the Anker PowerCore 10000mAh.  
\*battery pack is not provided.

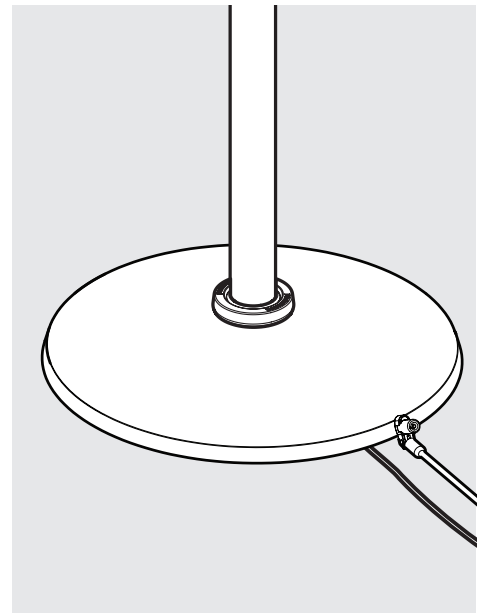
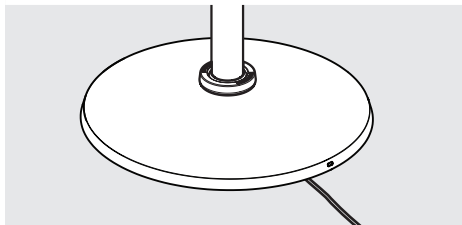
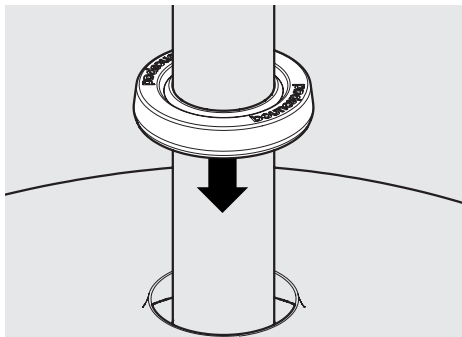

**9.2** If installing a battery pack, connect the Tablet Cable and locate the pack into the Floorstanding Base.

**10** With the Floorstanding Cover on the ground, locate & fit the Floorstanding Rubber Collar.

**11** Use a Kensington® Microsaver product to tether to a secure object. (refer to your Kensington® instructions for full details)

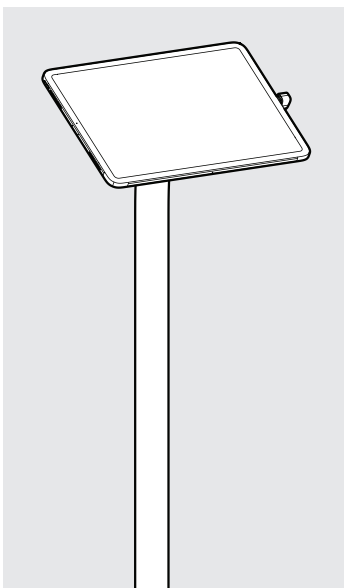

**12** Installation is now complete.